

P. 1 回転の角の大きさNo. 1

- 1 (1)
 (2)
 (3)
 (4)

P. 2 回転の角の大きさNo. 2

- 1 ① (1°) ② (10°) ③ (180°)
 2 ① (90°) ② (2直角で180度) ③ (270°)
 ④ (4直角で360度)

P. 3 回転の角の大きさNo. 3

- 1 ① (90°) ② (180°) ③ (270°) ④ (360°)
 2 ① (ア) ② (イ) ③ (イ) ④ (ア)

P. 4 回転の角の大きさNo. 4

- 1 ① (イ) ② (ア) ③ (ウ) ④ (エ)
 2 ① (180°) ② (360°) ③ (270°) ④ (90°)

P. 5 角度のはかり方A-No. 1

- 1 ① (40°) ② (70°) ③ (120°) ④ (150°)
 ⑤ (55°) ⑥ (165°)

P. 6 角度のはかり方A-No. 2

- 1 ① (50°) ② (30°) ③ (60°) ④ (80°)
 ⑤ (45°) ⑥ (65°)

P. 7 角度のはかり方A-No. 3

- 1 ① (130°) ② (160°) ③ (110°) ④ (140°)
 ⑤ (145°) ⑥ (125°)

P. 8 角度のはかり方A-No. 4

- 1 ① (65°) ② (105°) ③ (45°) ④ (160°)
 ⑤ (135°) ⑥ (75°)

402-2 小4SS角の大きさ

P. 9 角度のはかり方A-No.5

- 1 ① (70°) ② (45°) ③ (115°) ④ (150°)
 ⑤ (130°) ⑥ (85°)

P. 10 角度のはかり方A-No.6

- 1 ① (45°) ② (75°) ③ (120°) ④ (50°)
 ⑤ (165°) ⑥ (70°)

P. 11 角度のはかり方A-No.7

- 1 ① (65°) ② (105°) ③ (70°) ④ (165°)
 ⑤ (50°) ⑥ (135°)

P. 12 角度のはかり方A-No.8

- 1 ① (35°) ② (140°) ③ (155°) ④ (65°)
 ⑤ (70°) ⑥ (95°)

P. 13 角度のはかり方A-No.9

- 1 ① (40°) ② (50°) ③ (35°) ④ (85°)
 ⑤ (120°) ⑥ (150°)

P. 14 角度のはかり方A-No.10

- 1 ① (150°) ② (45°) ③ (35°) ④ (65°)
 ⑤ (120°) ⑥ (95°)

P. 15 角度のはかり方B-No.1

- 1 ① [式] $360-50=310$ 答え (310°)
 ② [式] $180+30=210$ 答え (210°)
 ③ [式] $360-80=280$ 答え (280°)
 ④ [式] $180+70=250$ 答え (250°)
 ⑤ [式] $360-140=220$ 答え (220°)
 ⑥ [式] $180+120=300$ 答え (300°)

402-2 小4SS角の大きさ

P. 16 角度のはかり方B-No. 2

- 1 ① [式] $360-40=320$ 答え (320°)
- ② [式] $180+50=230$ 答え (230°)
- ③ [式] $360-100=260$ 答え (260°)
- ④ [式] $180+110=290$ 答え (290°)
- ⑤ [式] $360-70=290$ 答え (290°)
- ⑥ [式] $180+40=220$ 答え (220°)

P. 17 角度のはかり方C-No. 1

- 1 ① [式] $360-60=300$, または $180+120=300$ 答え (300°)
- ② [式] $360-40=320$, または $180+140=320$ 答え (320°)
- ③ [式] $360-140=220$, または $180+40=220$ 答え (220°)
- ④ [式] $360-160=200$, または $180+20=200$ 答え (200°)
- ⑤ [式] $360-150=210$, または $180+30=210$ 答え (210°)
- ⑥ [式] $360-70=290$, または $180+110=290$ 答え (290°)

P. 18 角度のはかり方C-No. 2

- 1 ① [式] $360-70=290$, または $180+110=290$ 答え (290°)
- ② [式] $360-150=210$, または $180+30=210$ 答え (210°)
- ③ [式] $360-30=330$, または $180+150=330$ 答え (330°)
- ④ [式] $360-50=310$, または $180+130=310$ 答え (310°)
- ⑤ [式] $360-120=240$, または $180+60=240$ 答え (240°)
- ⑥ [式] $360-110=250$, または $180+70=250$ 答え (250°)

402-2 小4SS角の大きさ

P. 19 角度のはかり方C-No.3

- 1 ① [式] $360-30=330$, または $180+150=330$ 答え (330°)
 ② [式] $360-70=290$, または $180+110=290$ 答え (290°)
 ③ [式] $360-110=250$, または $180+70=250$ 答え (250°)
 ④ [式] $360-40=320$, または $180+140=320$ 答え (320°)
 ⑤ [式] $360-100=260$, または $180+80=260$ 答え (260°)
 ⑥ [式] $360-50=310$, または $180+130=310$ 答え (310°)

P. 20 向かい合った角No.1

- 1 ① (50°) (50°)
 ② (50°) [式] $180-130=50$ 答え (50°)
 (50°) [式] $180-130=50$ 答え (50°)

P. 21 向かい合った角No.2

- 1 ① (45°) ② (70°) ③ (35°) ④ (120°)
 ⑤ (48°) ⑥ (33°)

P. 22 向かい合った角No.3

- 1 ① (40°) ② (110°) ③ (95°) ④ (120°)
 ⑤ (80°) ⑥ (40°)

P. 23 向かい合った角No.4

- 1 ① (30°) ② (55°) ③ (110°) ④ (55°)
 ⑤ (65°) ⑥ (35°)

P. 24 角のかき方A-No.1

1 ①

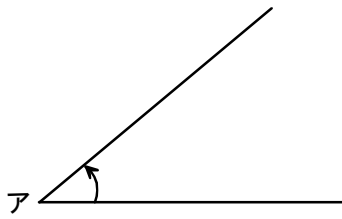

②

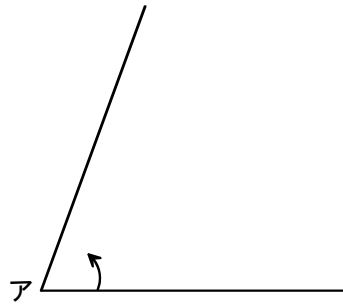

③

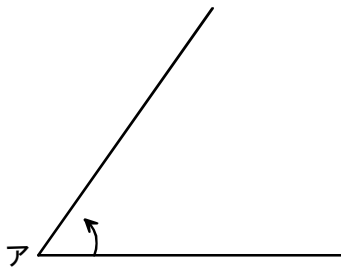

④

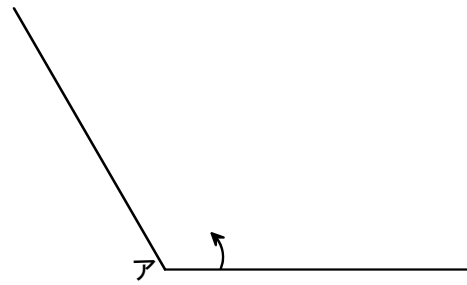

⑤

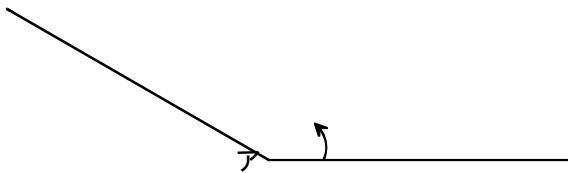

⑥

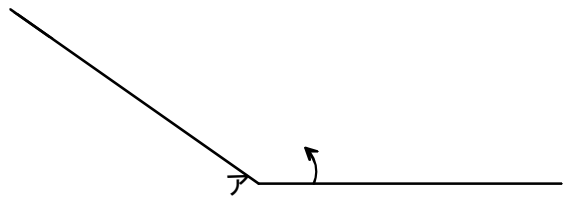

P. 25 角のかき方A-No. 2

1 ①

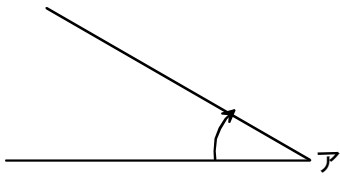

②

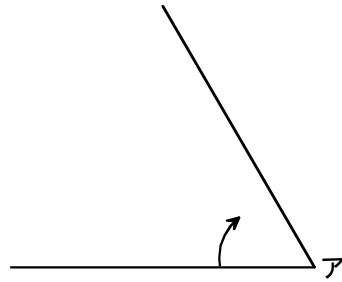

③

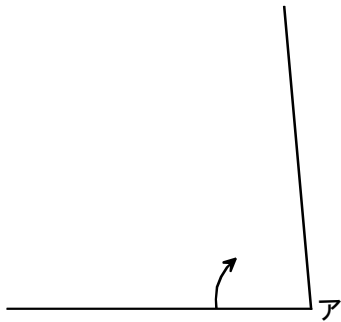

④

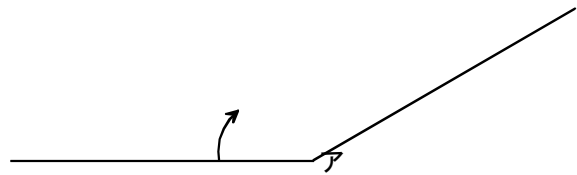

⑤

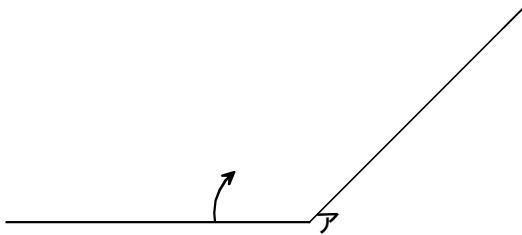

⑥

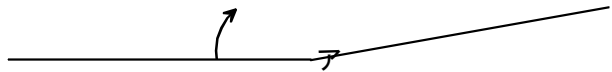

P. 26 角のかき方B-No. 1

1 ① 230 130

②

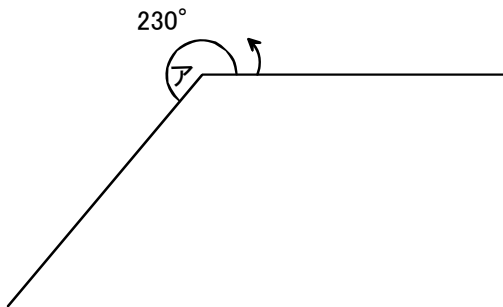

① 180 50

②

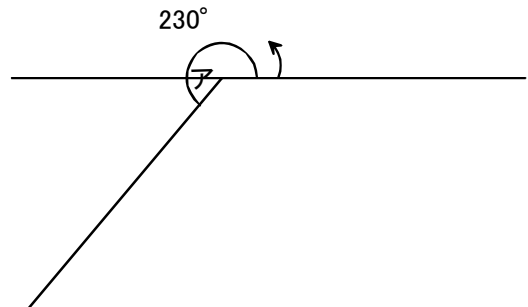

P. 27 角のかき方B-No. 2

1 ①

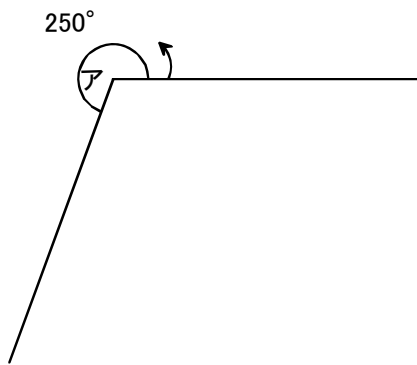

②

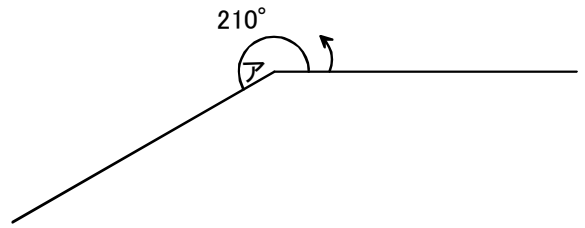

③

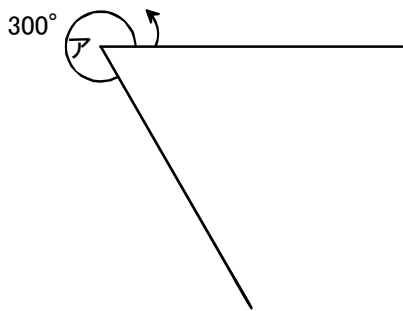

④

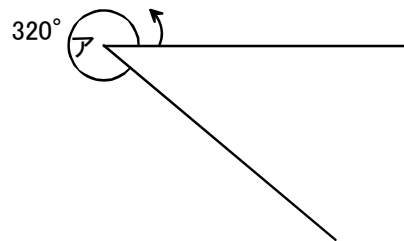

⑤

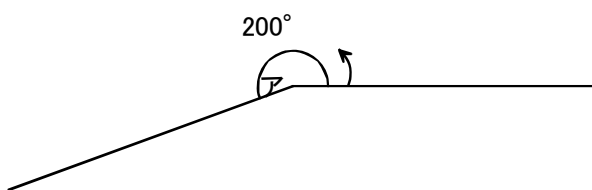

⑥

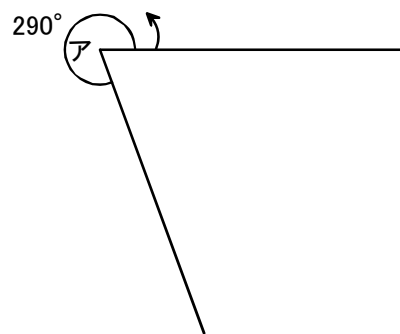

P. 28 角のかき方C-No.1

1 ①

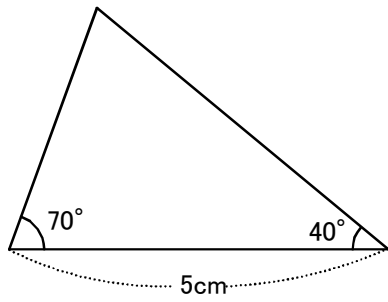

②

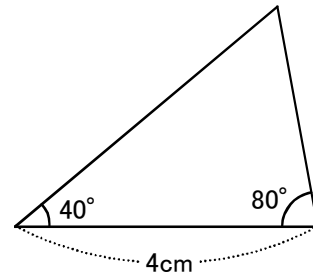

③

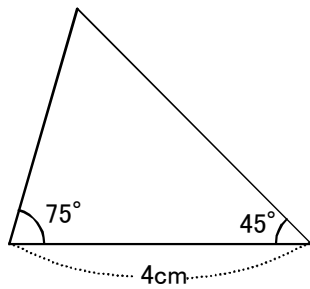

P. 29 三角じょうぎの角No.1

1 (あ) (60°) (え) (45°)

(い) (90°) (お) (90°)

(う) (30°) (か) (45°)

P. 30 三角じょうぎの角No.2

1 ① [式] $90+90=180$ 答え (180°)

② [式] $90+45=135$ 答え (135°)

③ [式] $90+45=135$ 答え (135°)

④ [式] $90+30=120$ 答え (120°)

⑤ [式] $90+60=150$ 答え (150°)

⑥ [式] $60+45=105$ 答え (105°)

P. 31 三角じょうぎの角No. 3

- 1 ① [式] $30+45=75$ 答え (75°)
 ② [式] $45+60=105$ 答え (105°)
 ③ [式] $60-45=15$ 答え (15°)
 ④ [式] $45-30=15$ 答え (15°)
 ⑤ [式] $90-45=45$ 答え (45°)
 ⑥ [式] $90-30=60$ 答え (60°)

【まとめの問題】 第1回 (1/3)

- 1 (1) (90°)
 (4) (360°)

- 2 ① (135°)
 ② (45°)
 ③ (15°)
 ④ (135°)

(2/3)

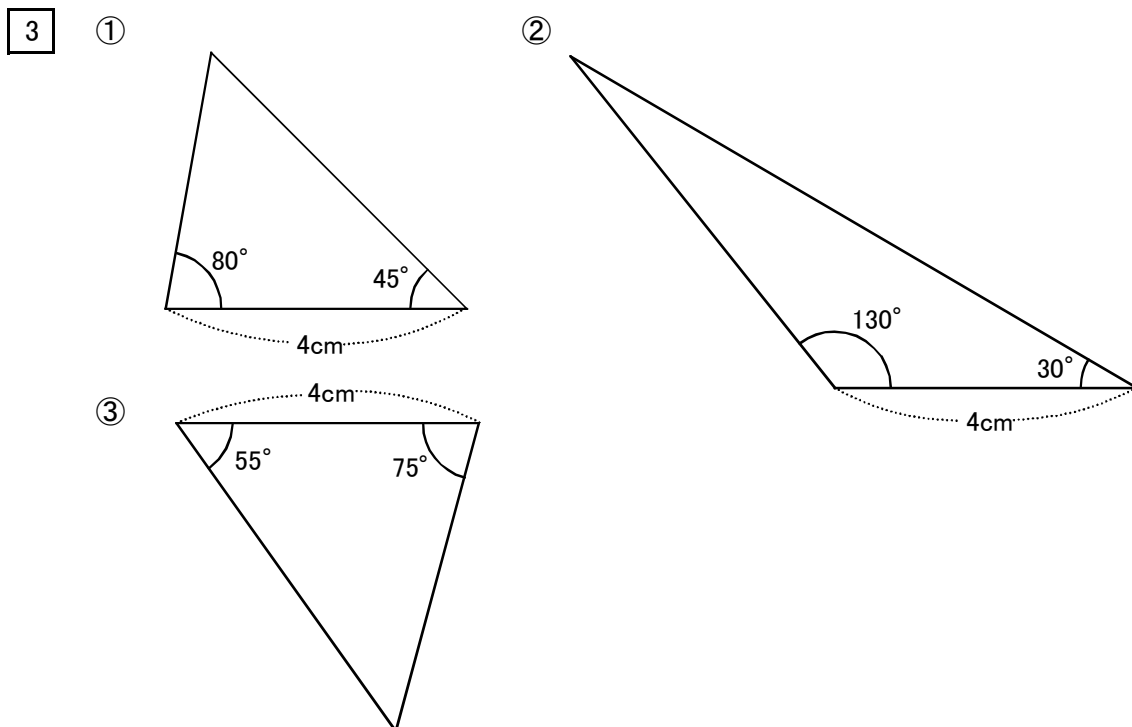

(3/3)

- 4 ① あ (70°) ② い (240°) ③ う (40°)

- 5 ①

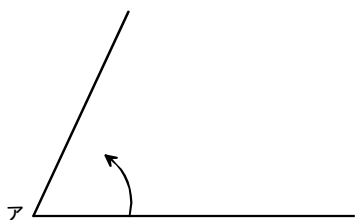

- ②

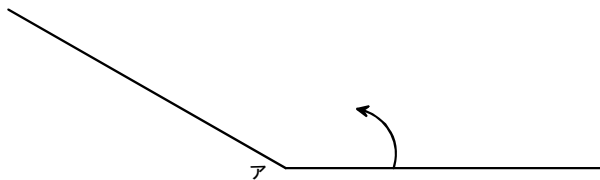

【まとめの問題】第2回(1/3)

- 1 (1) (90°)
 (2) (180°)

- 2 あ (105°)
 い (75°)
 う (15°)
 え (135°)

(2/3)

- 3 ①

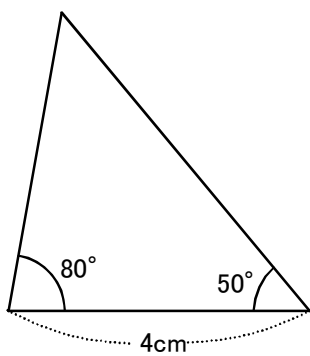

- ②

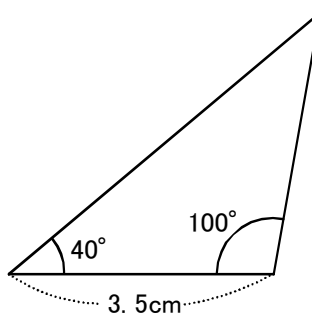

- ③

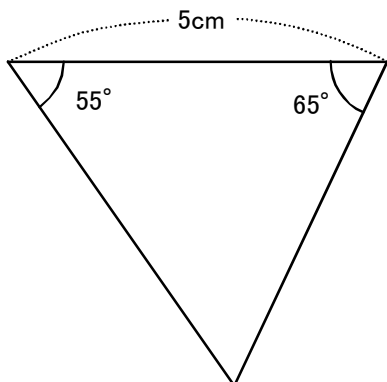

(3/3)

- ④ ① (あ) (140°) ② (い) (50°) ③ (う) (230°)

- ⑤ ①

